

Touch Sensor Dual Flush Plate

Installation & Operation Instructions

Please read completely before commencing. Retain for future reference

TR9016

Introduction

This sensor flush plate is compatible with wall hung frame cisterns and In-wall cisterns from Roper Rhodes Group.

For In-wall installation the front of frame to front of finished wall minimum depth should be 15.5mm. If used with a furniture concealed cistern ensure a clearance of 105mm is left between the cistern and the front of the furniture fascia surface to allow adequate installation.

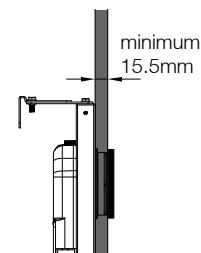

Battery Installation (Batteries not included)

Open the glass plate by pushing it towards the top and then tilting it forwards. The clip chain will allow it to hang, make sure it's secured before dropping it.

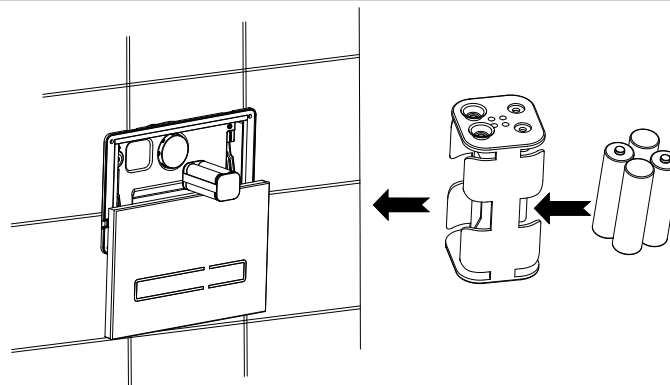
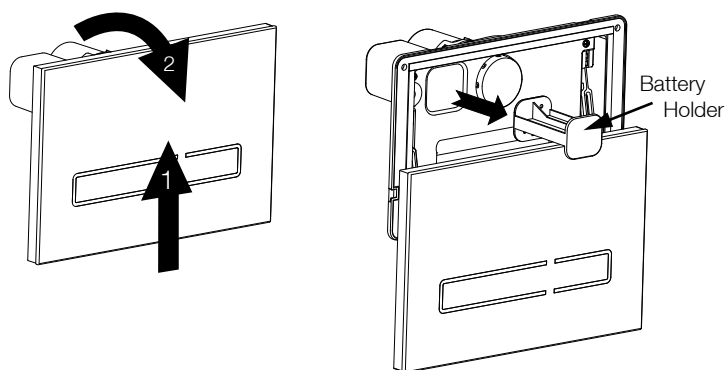

Good quality Alkaline batteries will last for approximately one year in normal domestic conditions.

Once batteries are due to be replaced, a continuous alarm will be heard for 10s, indicating that battery power is low and that they are due to be changed. The LED lights will also flash.

Remove the battery holder and insert 4x AA batteries into the battery compartment, noting the polarity on the battery holder. Slide back into place and replace the glass fascia. The LEDs will illuminate, indicating that the flush plate is ready to be used.

Batteries are totally exhausted when the LED lights are continuously flashing (twice per second). Please replace the batteries immediately.

A manual over-ride button is available if batteries are totally exhausted.

Installation

1. Cut the protective casing of the in-wall cistern in-line with the finished wall surface.

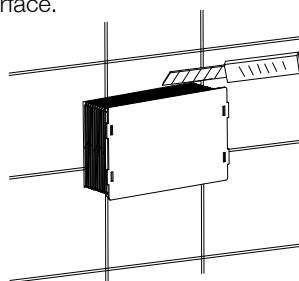

2. Screw the fixing arms (supplied in the box) onto the cistern. The rods may need cutting down depending on the thickness of the finished wall/surface.

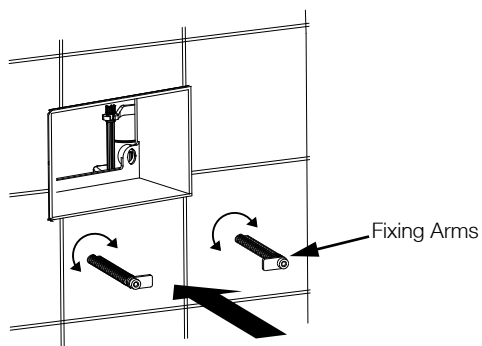

3. Remove the front fascia panel completely. Push the glass front to the top and tilt the top towards you. Un-clip the glass fascia by expanding the clip links and keep aside until installation is completed. Remove the battery holder also to **avoid damage**.

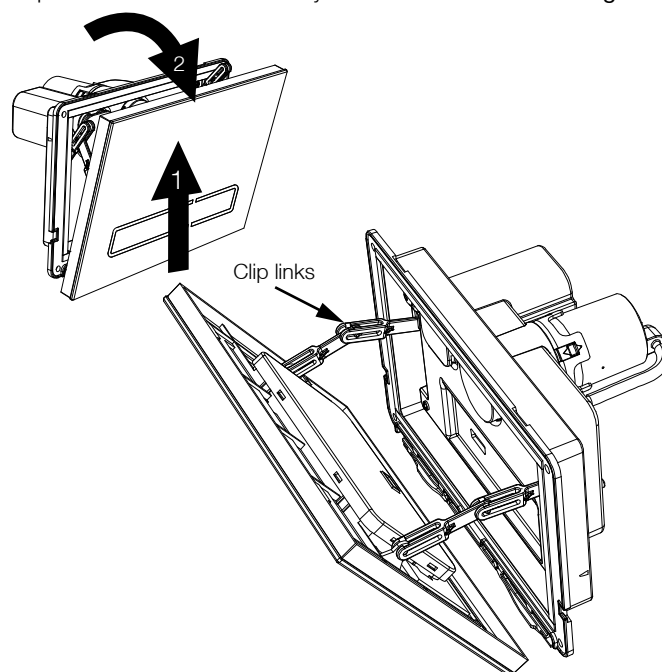

Touch Sensor Dual Flush Plate

Installation & Operation Instructions

Please read completely before commencing. Retain for future reference

△ TR9016

4. Connect the air hoses from the cistern to the flush plate as shown. Attach the blue hose to the half moon symbol and the transparent hose to the full moon symbol.

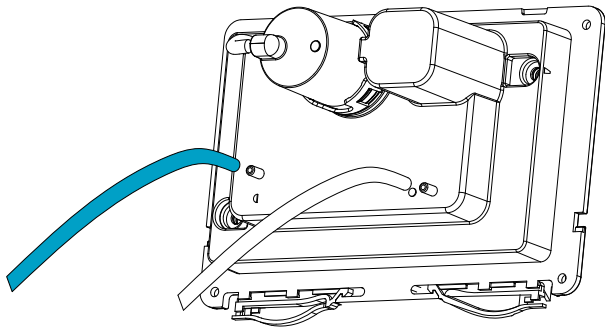

5. Make sure the cistern is fully commissioned before mounting the bracket in place.

Locate the mounting bracket onto the fixing arms and secure the top left and bottom right corners with the screws provided and tighten with a screwdriver. Be careful not to overtighten.

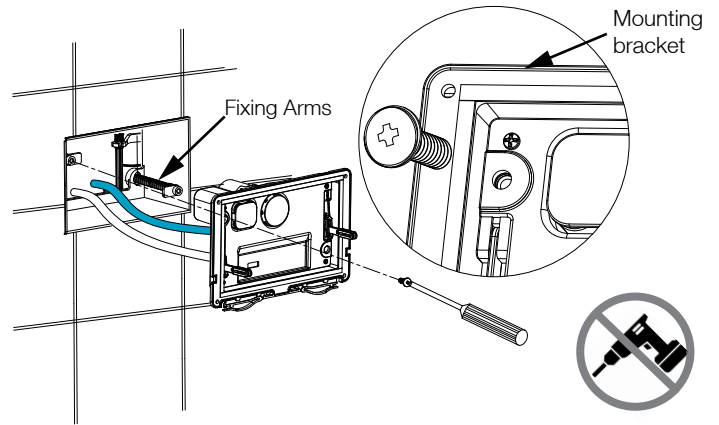

Re-connect the clip links and cable ribbon to the glass fascia and insert the battery holder. Place the front glass plate and remove the protective film prior to testing its functioning. Once correctly attached the flush plate will illuminate for a couple of seconds.

Operation

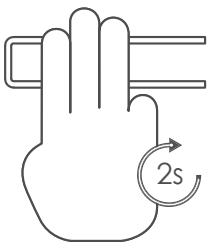

Three Finger Activation: Use a minimum of three fingers touching the sensor for two seconds to activate.

Full / Reduced Flush

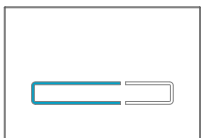

Full Flush: Touch the longer decal side with three fingers for two seconds to activate the flush. The LED lights will illuminate.



Reduced Flush: Touch the shorter decal side with three fingers for two seconds to activate the flush. The LED lights will illuminate.

If the flush plate is touched for more than 5 seconds and still won't flush, please refer to the 'Troubleshoot' document.

Manual over-ride

If batteries are exhausted completely, the glass fascia can be removed to reveal the manual flush button.

The manual over-ride is not intended as a long term solution. When using the manual push button, un-plug the cable ribbon and take the front glass fascia off the chain links. Keep safe to prevent damage.

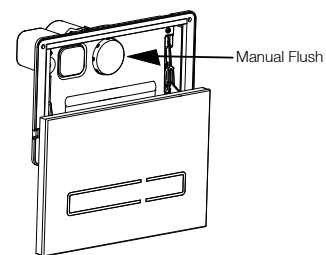

Specification

Batteries: 4x AA (LR6) Alkaline Batteries (Not supplied)

Ingress Protection: IPX4

At the end of life, please dispose of batteries and unit where municipal recycling facilities exist. Do not dispose of in the regular waste.

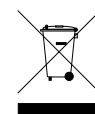

Brought to you by the Roper Rhodes Group
Brassmill Lane Trading Estate
Bath
BA1 3JF
t: 01225 303900